

Mrs Mayet & Mrs Adel

Lengths and Angles in Shapes

Introduction

What do you know about the angles in this shape?

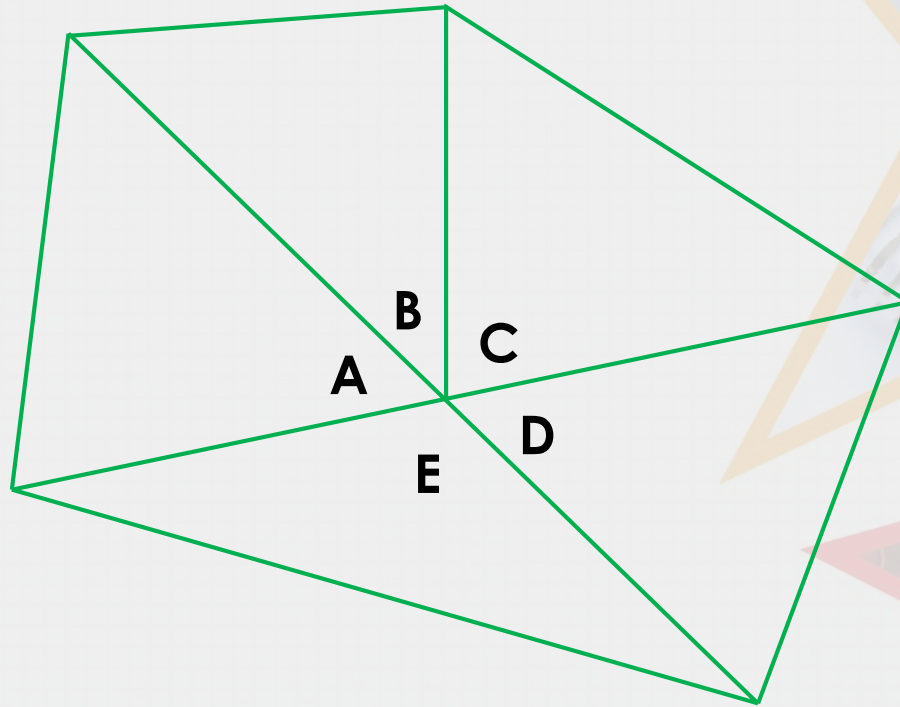

Introduction

What do you know about the angles in this shape?

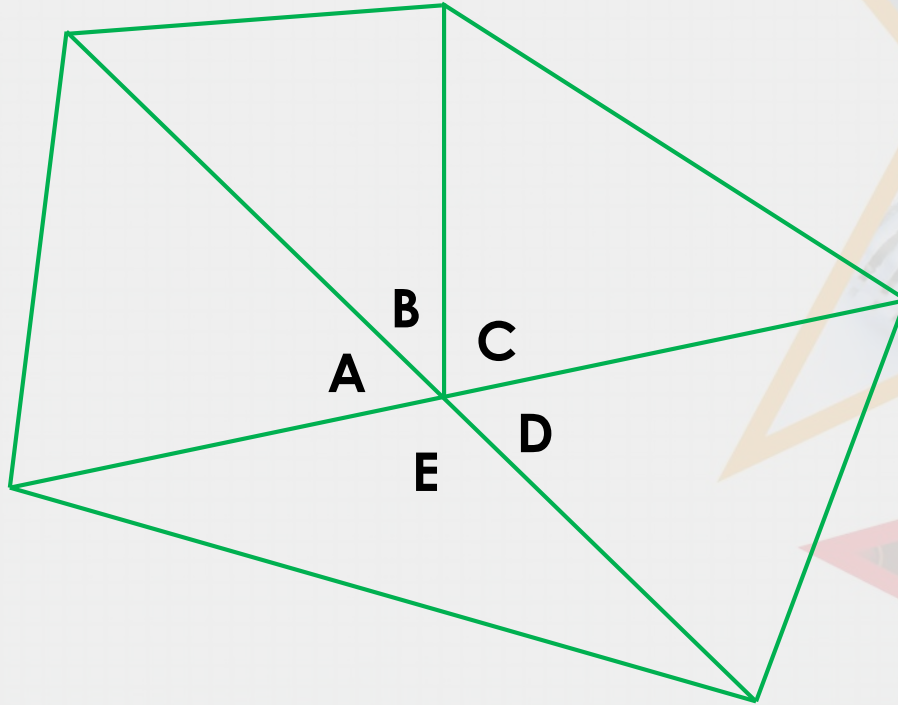

Various answers, for example:

$$A + B + C + D + E = 360^\circ$$

$$A + B + C = 180^\circ$$

$$E + D = 180^\circ$$

$$B + C + D = 180^\circ$$

$$A + E = 180^\circ$$

Varied Fluency 1

Calculate the length of side A and side B.

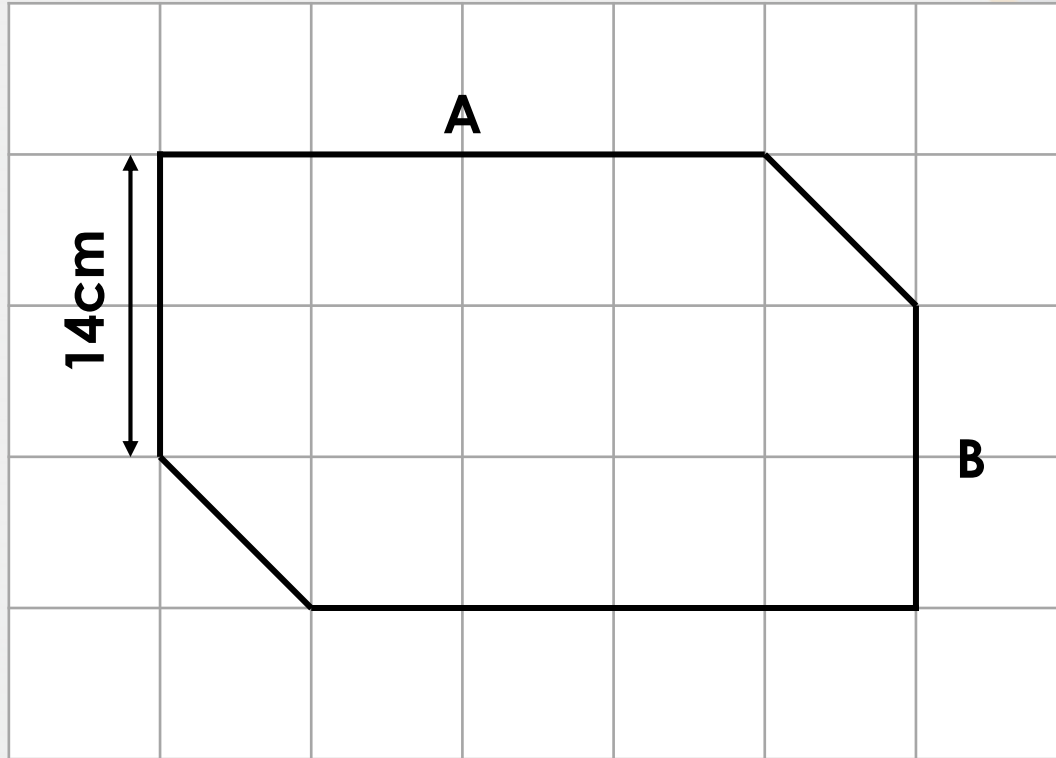

Varied Fluency 1

Calculate the length of side A and side B.

A = 28cm, B = 14cm

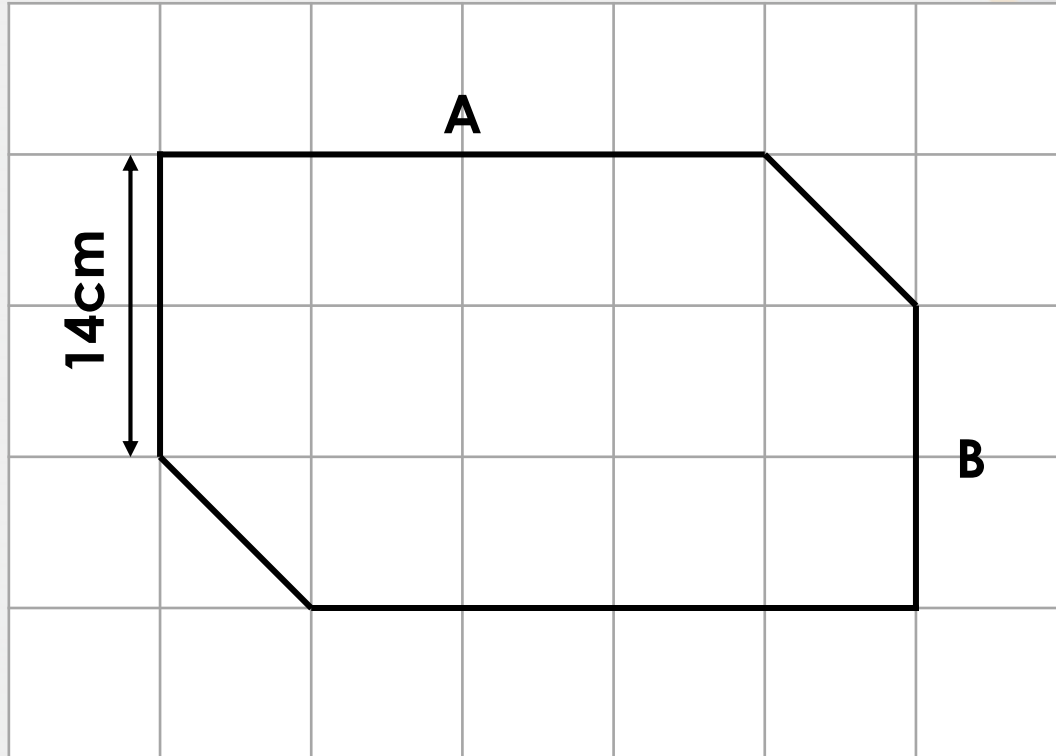

Varied Fluency 2

Calculate the angles of A, B, C and D.

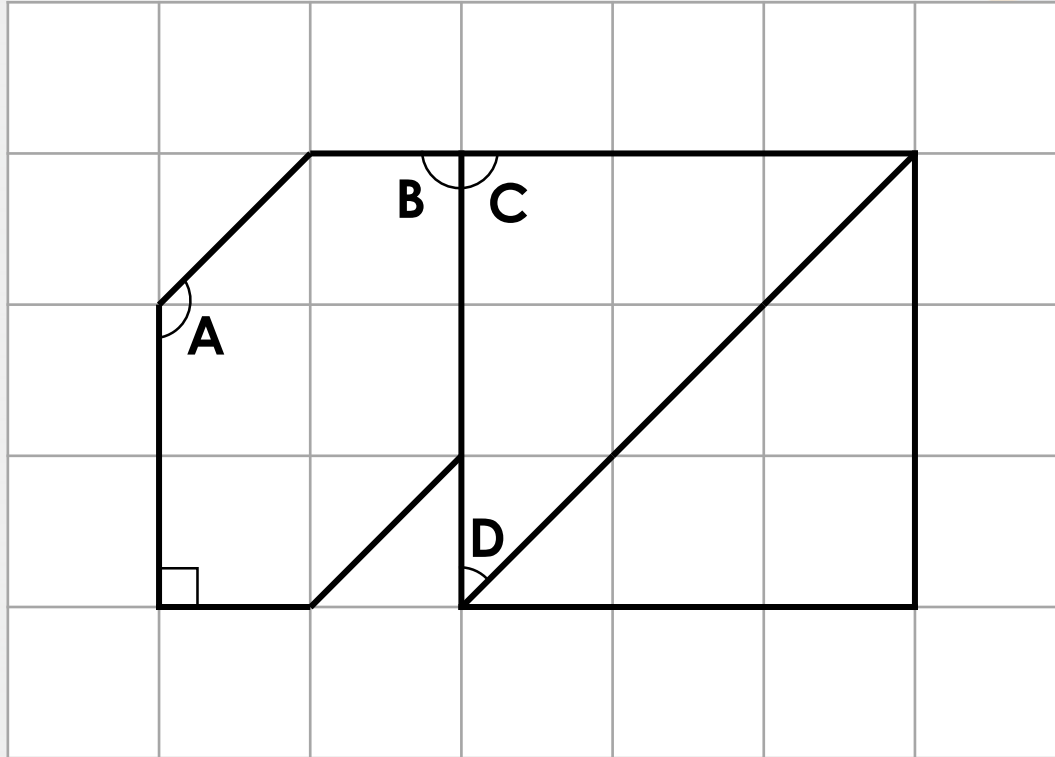

Varied Fluency 2

Calculate the angles of A, B, C and D.

A = 135°; B = 90°; C = 90°; D = 45°

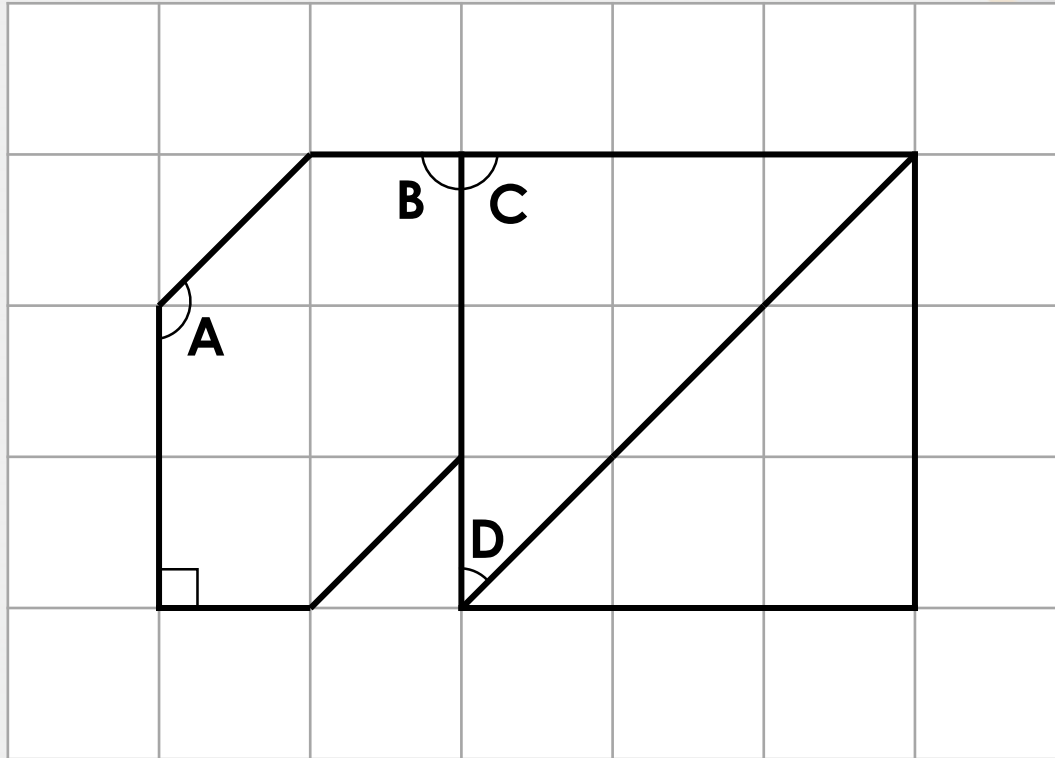

Varied Fluency 3

Side A is 16cm. True or false?

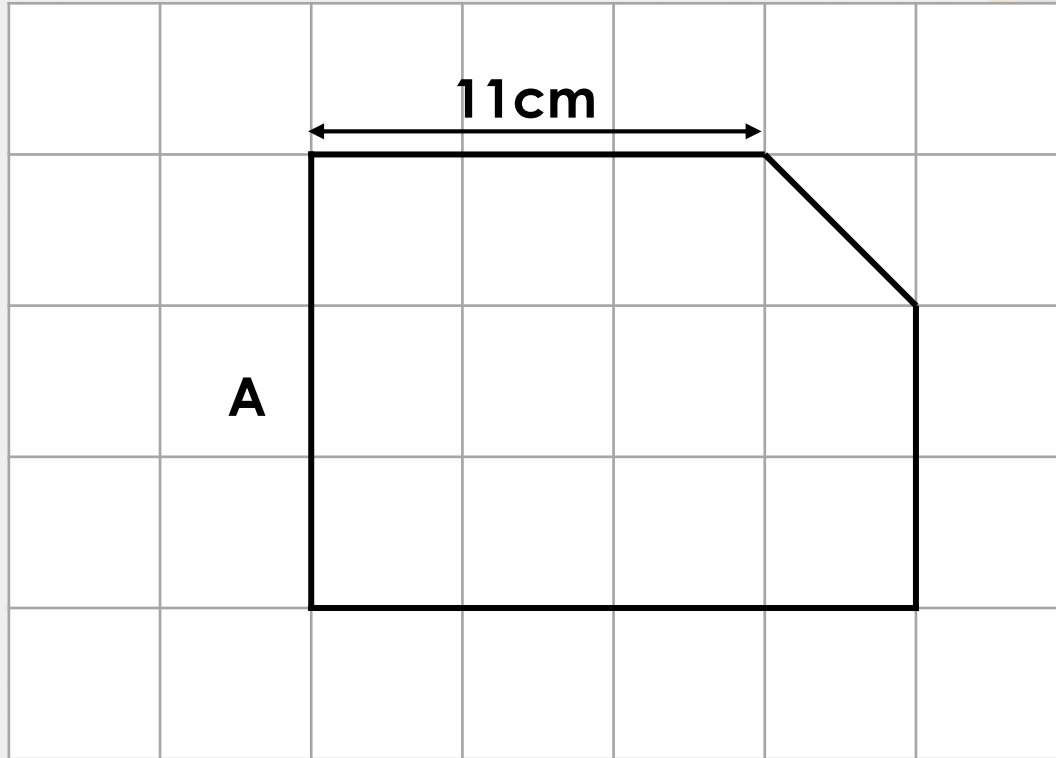

Varied Fluency 3

Side A is 16cm. True or false?

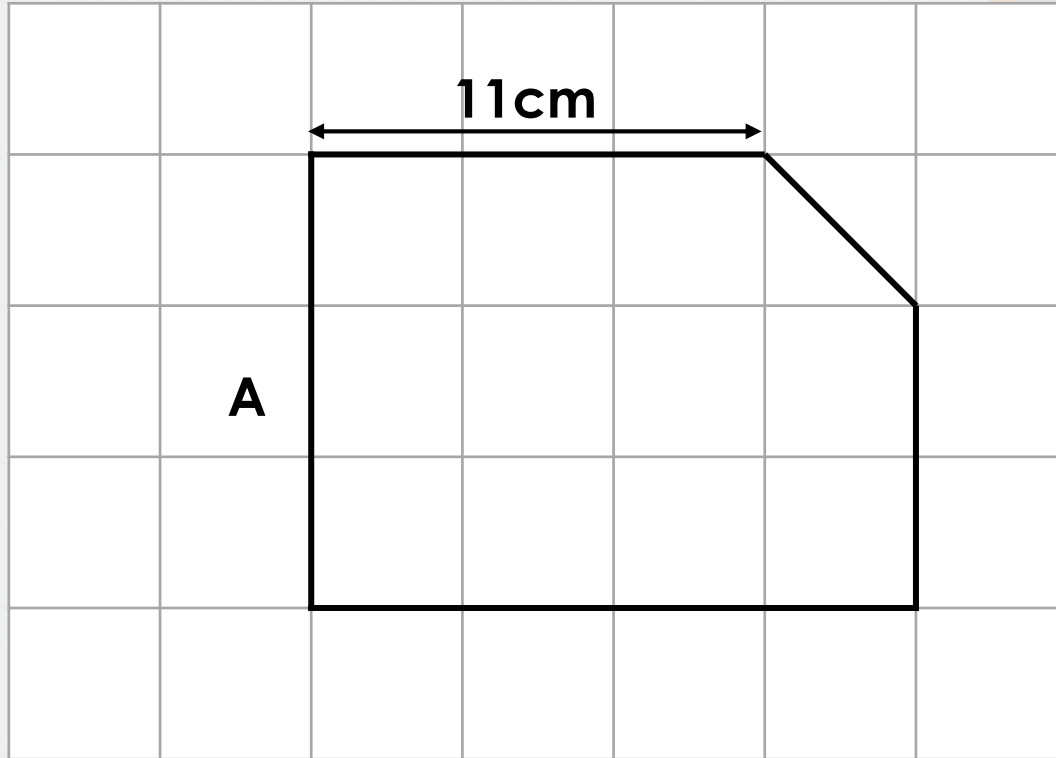

False, side A is 11cm

Varied Fluency 4

Match the angles and lengths to the shape.

1. 18cm
2. 135°
3. 10cm
4. 90°

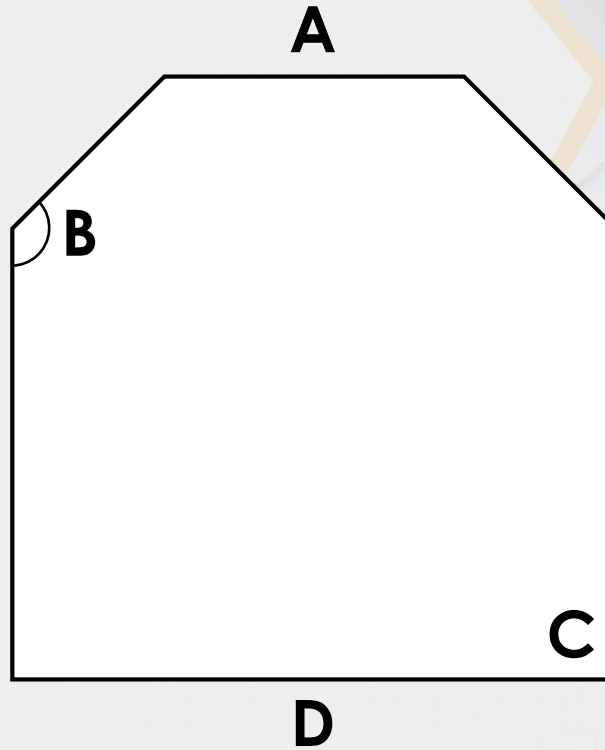

Varied Fluency 4

Match the angles and lengths to the shape.

1. 18cm - D
2. 135° - B
3. 10cm - A
4. 90° - C

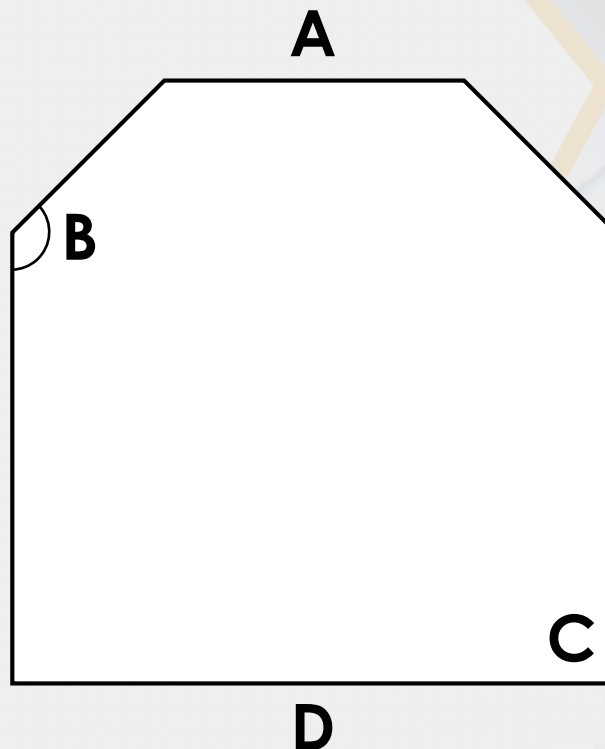

Reasoning 1

Adam thinks he has chosen the correct degrees for the total of angle A and angle B.

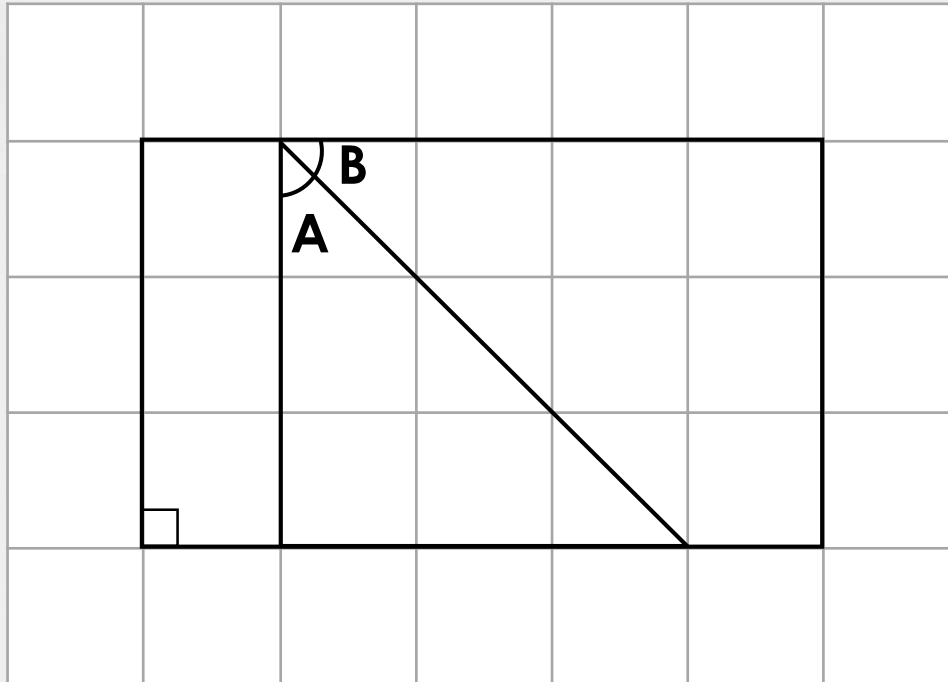

135° ✓

270°

90°

Do you agree? Explain why.

Reasoning 1

Adam thinks he has chosen the correct degrees for the total of angle A and angle B.

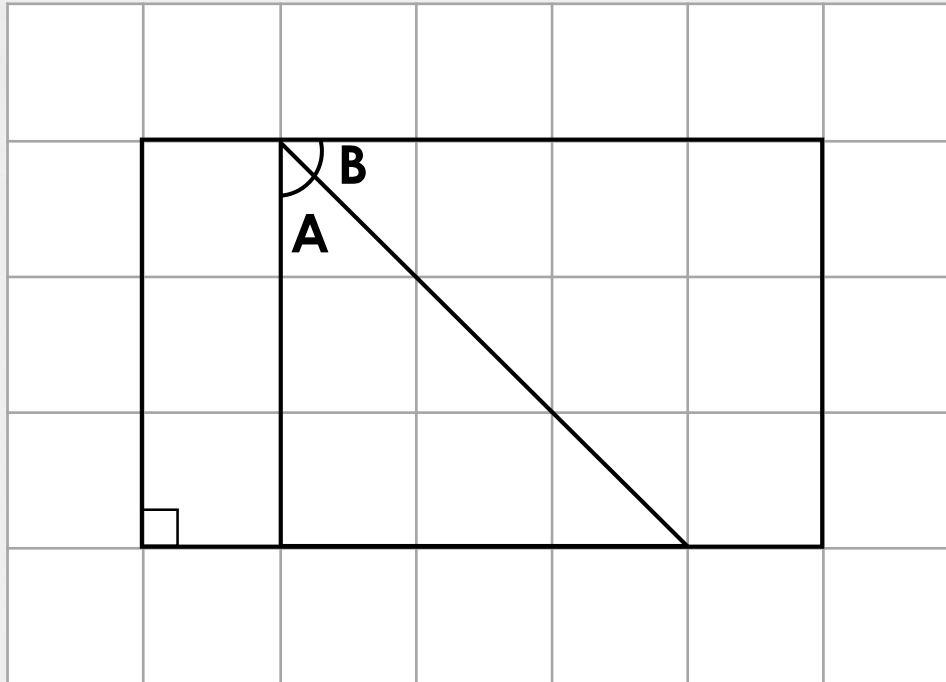

135° ✓

270°

90°

Do you agree? Explain why.
Adam is not correct because...

Reasoning 1

Adam thinks he has chosen the correct degrees for the total of angle A and angle B.

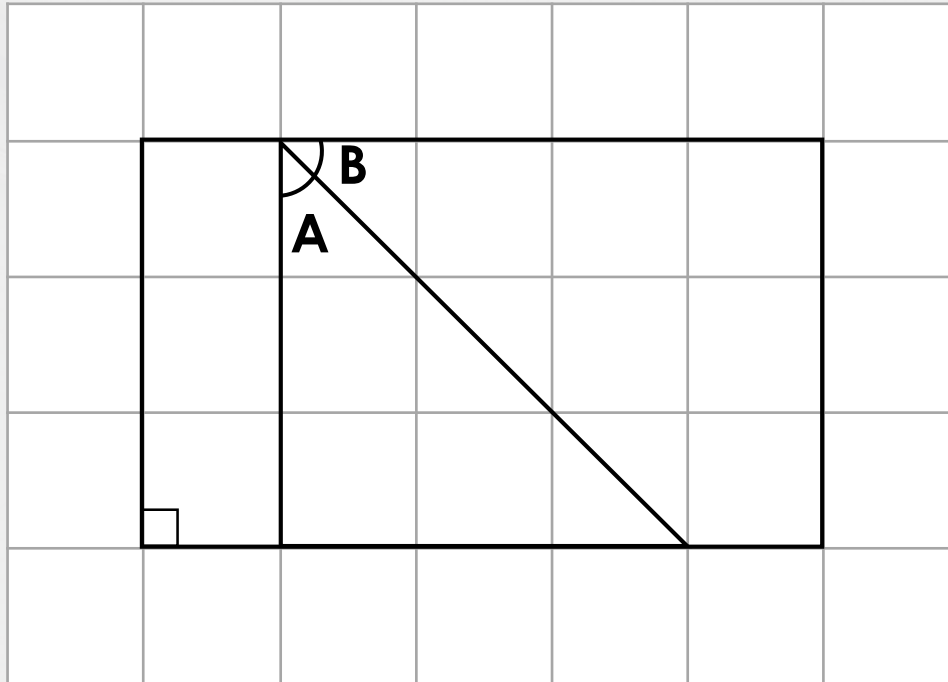

135° ✓

270°

90°

Do you agree? Explain why.

Adam is not correct because each angle is 45° . $45^\circ + 45^\circ = 90^\circ$

Problem Solving 1

**Amélie has a rectangle with a perimeter of 34cm.
Sides A and C are 3cm shorter than sides B and D.**

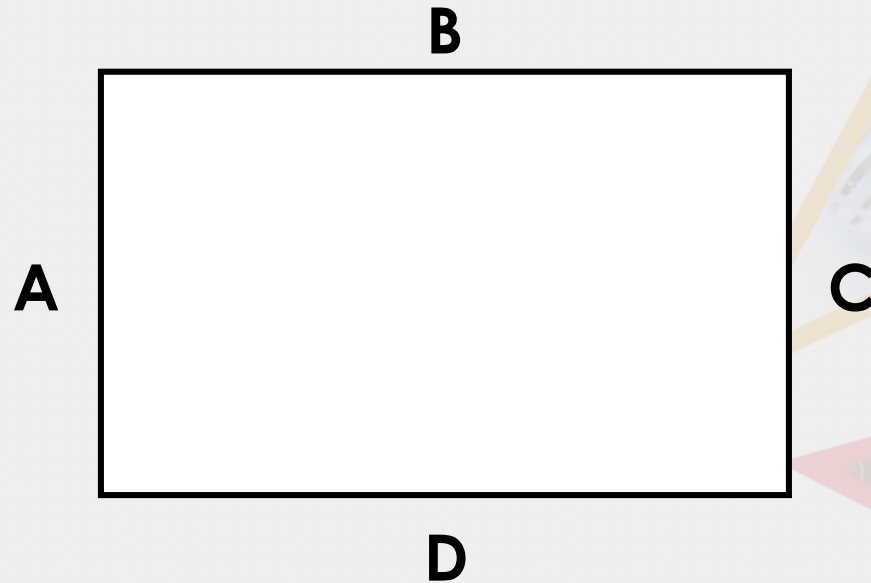

What length is each side?

Problem Solving 1

Amélie has a rectangle with a perimeter of 34cm.
Sides A and C are 3cm shorter than sides B and D.

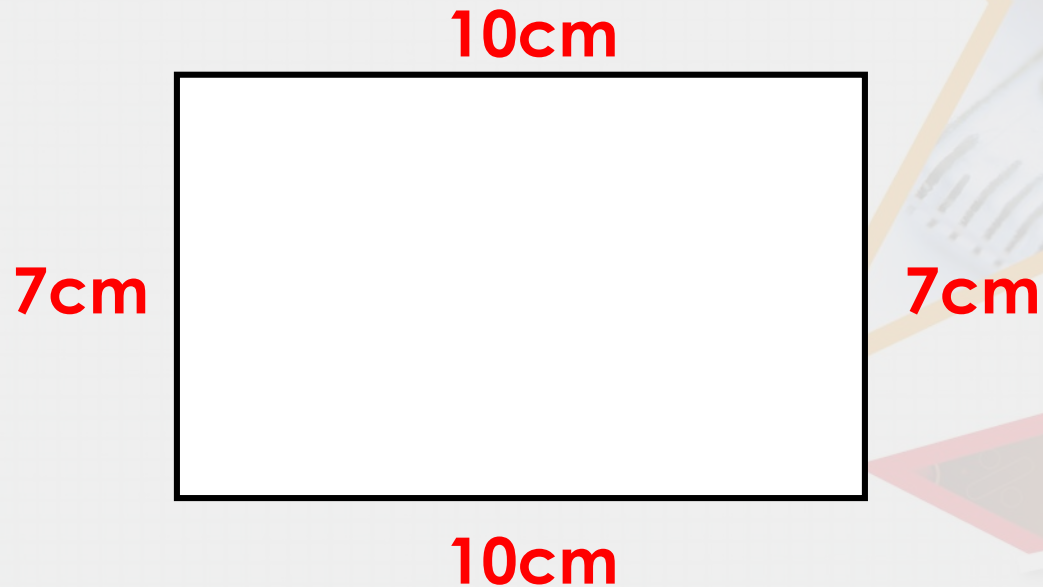

What length is each side?

Reasoning 2

Shane and Elizabeth are calculating angles in a shape.



Shane

A right angle split into 3 will always have 3 angles of 30° .

A right angle split into 3 can have any 3 angles with a sum of 90° .

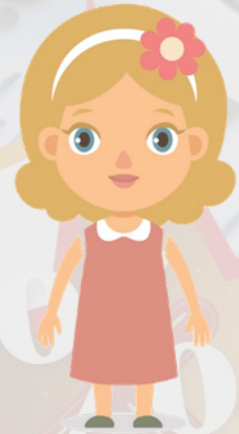

Elizabeth

Who is correct? Why?

Reasoning 2

Shane and Elizabeth are calculating angles in a shape.



Shane

A right angle split into 3 will always have 3 angles of 30° .

A right angle split into 3 can have any 3 angles with a sum of 90° .

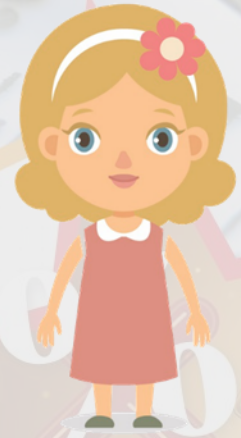

Elizabeth

Who is correct? Why?

Elizabeth is correct because...

Shane is not correct because...

Reasoning 2

Shane and Elizabeth are calculating angles in a shape.



Shane

A right angle split into 3 will always have 3 angles of 30° .

A right angle split into 3 can have any 3 angles with a sum of 90° .

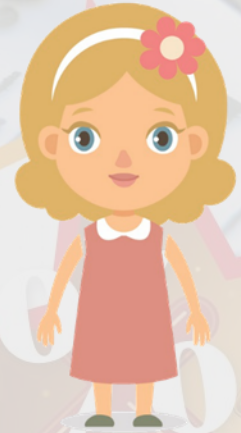

Elizabeth

Who is correct? Why?

Elizabeth is correct because as long as the angles add up to 90° , the angles can be any size.

Shane is not correct because a right angle split into 3 would only have 30° angles if they were split equally.